

Cifa Spritz System 3 CSS-3 C

SPRAYED CONCRETE BOOM PUMP ON CRAWLER

Shotcrete Boom
Pumping Unit
Shotcrete operated
Chassis

CSS-3
PAS 255 ET
Electric
Crawler



Dimensions and Performances

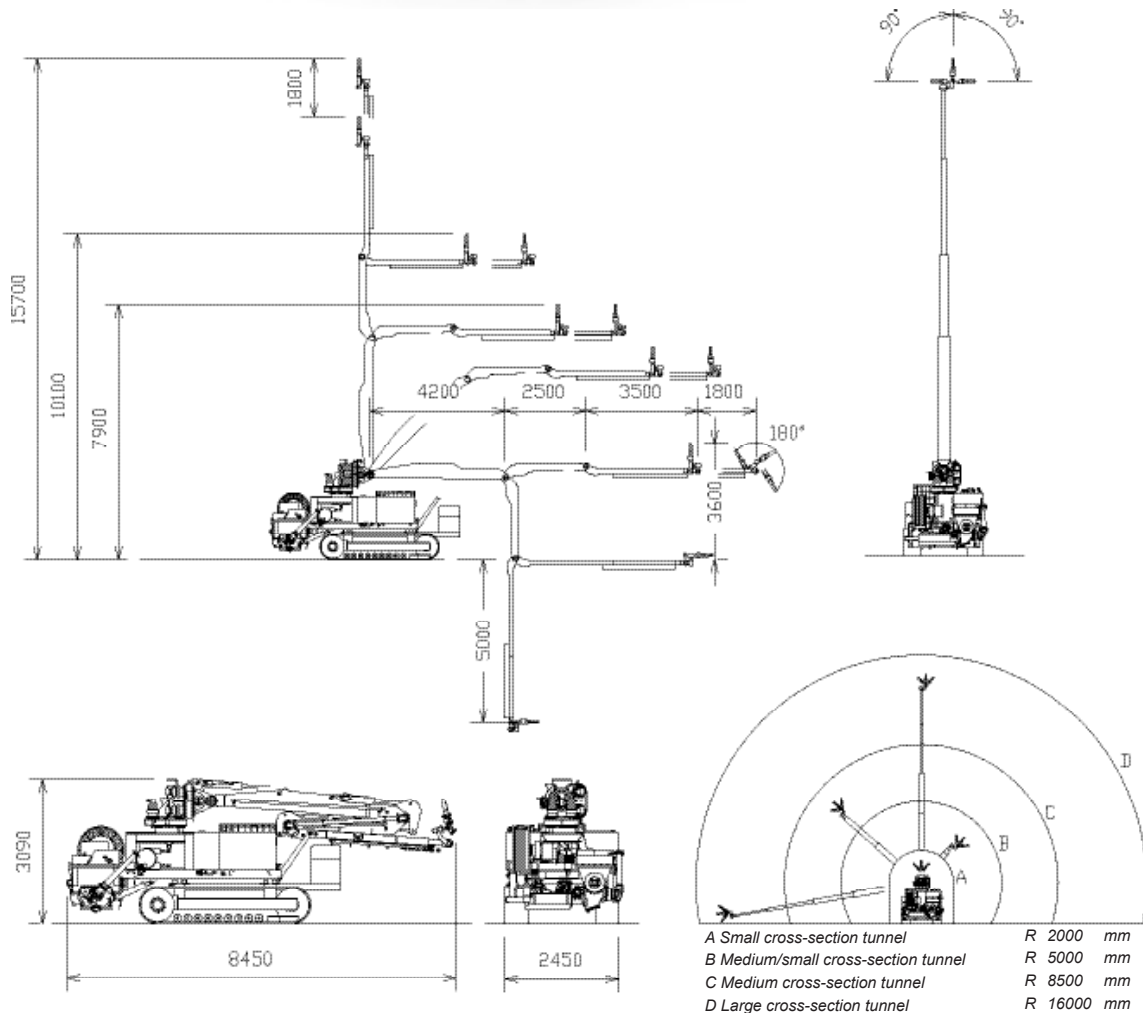

Cifa Spritz System 3 CSS-3 C

SPRAYED CONCRETE BOOM PUMP ON CRAWLER

Shotcrete Boom	CSS-3
Pumping Unit	PAS 255 ET
Shotcrete operated	Electric
Chassis	Crawler

Standard equipment

- Uniflux EAS 2.0 dosing system, with peristaltic pump with electric drive and electronic management, configurable in two output to meet the requirements of different flow rates. Suitable for all types of liquid additives. Keeps the preset percentage of additive constant, even when the pumping parameters of the concrete change
- Hydraulically returned wind cable device, with 50 m cable
- Water tank (600 L)
- Setting accelerator tanks (1000 L)
- Electric vibrator fitted to the grid
- n°1 Proportional radio-remote control
- Hydraulically controlled high pressure water pump (16 L/min – 120 bars), with washing nozzle and 15 m of pipe
- Catalytic silencer
- Nebulization fluid handpump for concrete anti-adhesion protection (10 L)
- Automatic lubrication in 8 points for valve, pumping group mixer and turret
- N°6 x 45W-4800 lumen xenon working light on the turret
- Nozzle brush movement
- One colour painting, RAL 2000

Optional

- Additives heating system
- Anti-particulate filter (FAP)
- ATEX configuration
- Rubber covers for crawler

Pumping Unit Technical Data

Model		PAS 255
Theoretical output (Min ÷ Max)	<i>m³/h</i>	5 ÷ 25
Max. pressure on concrete	<i>bar</i>	50
Max. number of cycles per minute	<i>n°</i>	16
Concrete cylinders (diam. x stroke)	<i>mm</i>	176X660
Hopper capacity	<i>L</i>	300
Installed power (electric)	<i>kW</i>	45

Placing Boom Technical Data

Model		CSS-3
Turret vertical rotation angle		±180°
Turret horizontal rotation angle		±180°
1st section lifting angle		+90° -5°
2nd section lifting angle		180°
3rd section lifting angle		270°
3rd section telescopic extension	<i>m</i>	1,8
Longitudinal nozzle rotation		180°
Transversal nozzle rotation		±90°

Dosing System Technical Data

Model		Uniflux 2
Theoretical output (Min ÷ Max)	<i>l/min</i>	1 ÷ 16
Max pressure	<i>bar</i>	13
Setting accelerator tanks	<i>l</i>	1000

Crawler Technical Data

Model		Gemmo Group
Diesel Motor		Hatz 4L41C
Installed power	<i>kW</i>	48,5
Max Speed	<i>Km/h</i>	1,5
Max slope	<i>%</i>	75
Winch capacity	<i>Kg</i>	20000
Fuel tank	<i>L</i>	30
Weight	<i>Kg</i>	18000

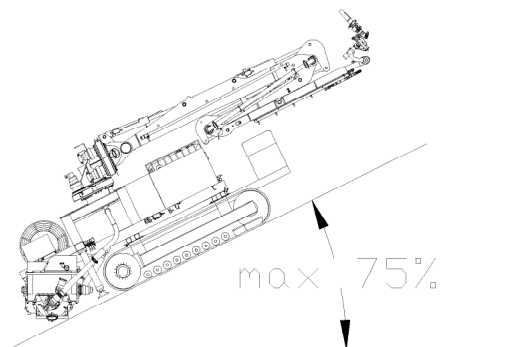

Technical data and characteristics subject to modifications without notice