

# HITACHI EX 200R

## Specifications Mini Excavator

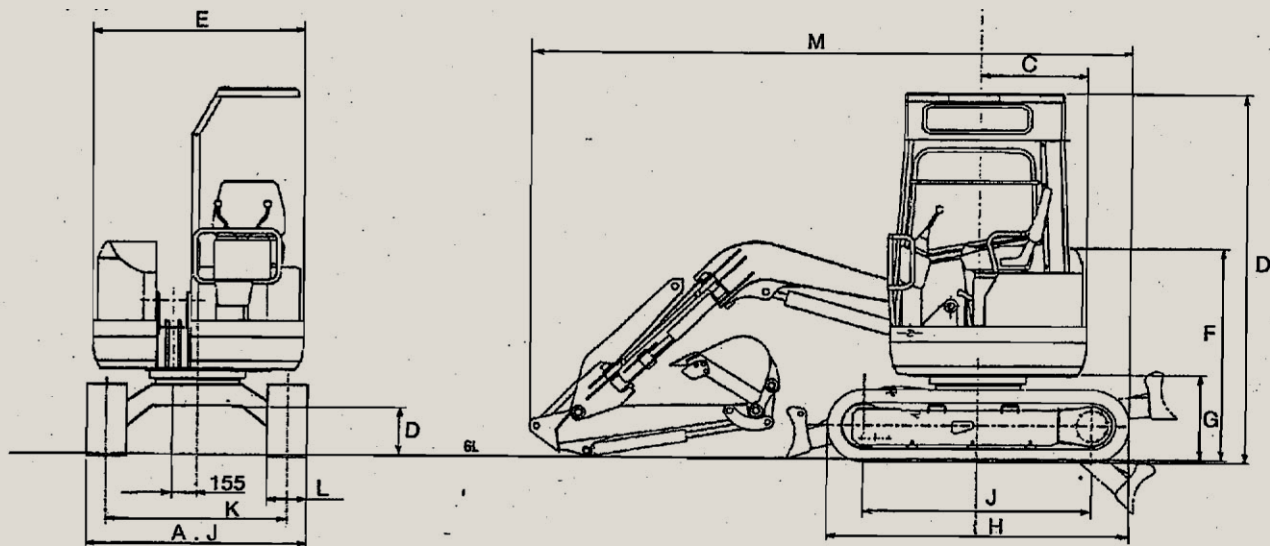



<b>Main Spec.</b>		
Operating weight	(kg)	2100 (RS). 2180 (STS)
Std. bkt. capacity	(m3)	0.05/
Std. bkt. width	(mm)	400
<b>Dimensions (mm)</b>		
Overall length	A	3700
Rear end radius	B	660
Std. shoe width	C	250
Track length	D	1450
Crawler length	(D)	1860
UC width	E	1380
Track gauge	F	1130
Overall height	G	2290
Overall width	H	1380
Ground clearance	I	295
Std arm length		N/A
<b>Engine</b>		
Manufacturer		ISZ
Model		3KC1
Rated output	(kW(PS)/rpm)	12.5{17}/2400
Max torque	(N-m/min-1)	N/A
No. of cylinders		N/A
Bore x stroke		N/A
Dislacement	(ltr.)	1.0
<b>Hyd. System</b>		
Relief valve setting	(Mpa)	17.2
Hyd.pump type x qty.		GPx2, GPx1

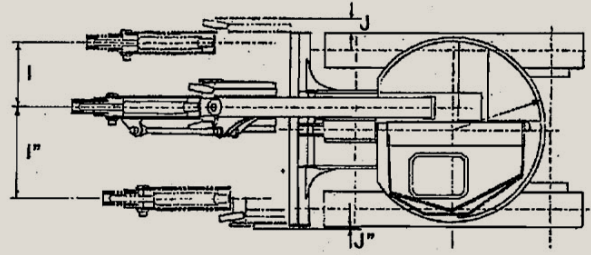
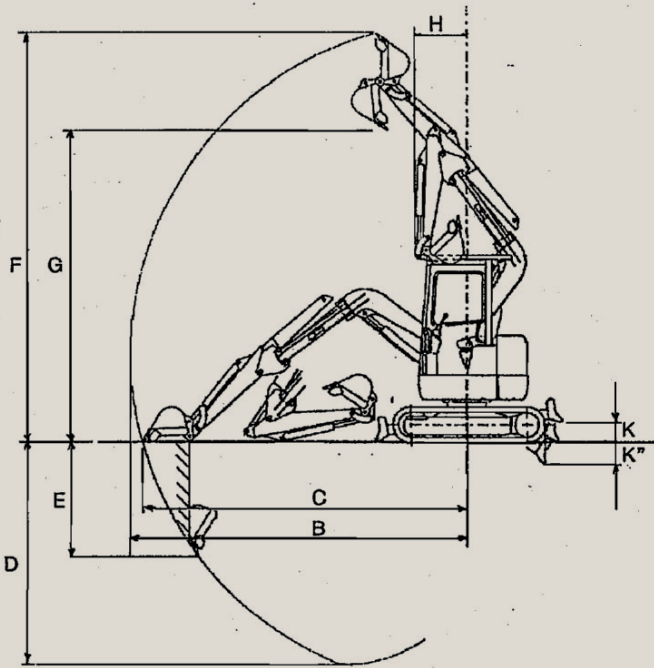

<b>Performance</b>		
Gradeability	(deg)	30
Arm crowd force	(kN)	N/A
Bkt. digging force	(kN)	16.7/
Max digging depth	(mm) U	2250
Max digging depth (P)	(mm) V	1810
Max digging reach	(mm) W	3995
Max dig. reach at GL	(mm) X	N/A
Max dumping clearance	(mm) Y	3510
Max digging height	(mm) Z	4700
Min swing radius	(mm)	650
Travel speed	(km/h)	1.5
Swing speed	(min-1)	9.0
Boom offset distance	(mm)	N/A
Boom swing angle	(deg)	N/A
<b>Equipment Structure</b>		
Blade width x height	(mm)	1380 x 300
Std. shoe type		RS, S
<b>Capacity of Oil</b>		
Fuel tank	(ltr)	20
Hydraulic oil tank	(ltr)	30
<b>Others</b>		
Remarks		N/A